

Plate



Front view installed



Back view installed

Specifications

General

Material	Galvanised Steel, 2.0mm thick
Includes	1x Plate and 4x Screws
Compliance	When paired with the corresponding CUBO Flush Mounted Switchboard, provides mechanical protection at a minimum requirement of WSX3 for wiring systems positioned behind the switchboard, concealed near building surfaces. [Please see Sections 3.9.4.2, 3.9.4.4, and Appendix H5.4 of AS/NZS 3000 for further details].

Dimensions

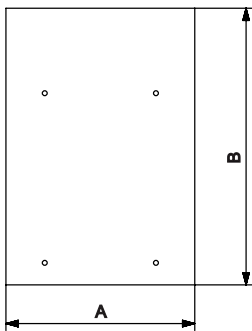

METAL PLATE

MODEL	A [mm]	B [mm]
PSF12W-P	270	325
PSF18W-P	378	325
PSF24W-P	270	490
PSF36W-P	270	615

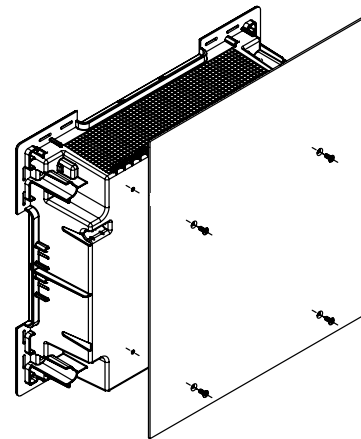

The section that extends outside the frame of the board is to protect the incoming mains cables. The plate can be reoriented to suit either direction.