

# VOLTEX®

## INSTALLATION GUIDE

### Voltex Push Button / Rotary Dimmer (Trailing Edge) DM300S

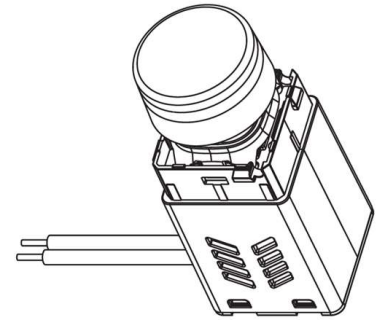

This product should only be installed by a licenced electrician in accordance with all the requirements of AS/NZS 3000 [current edition] and other relevant Standards and Regulations

#### Technical specifications

<b>Nominal Supply Voltage</b>	230-240Vac 50Hz
<b>Maximum Load</b>	300W
<b>Minimum Load</b>	3W
<b>Inbuilt switch type</b>	Semi-conductor switching device. Circuit on the load side should always be considered as live
<b>Compatible loads*</b>	Dimmable LED light fixtures [trailing edge] 240V incandescent/halogen 12V halogen c/w electronic transformer [trailing edge]
<b>Non-compatible loads*</b>	Non-dimmable lighting loads Many brands of dimmable LED globes 12V halogen lamps with Iron core transformers Motor loads (ceiling fans, etc) Mixed load type
<b>Over-temperature protection</b>	Voltage maintained non-self-resetting thermal cut-out
<b>Product Certification</b>	AS/NZS 60669.2.1 with AS/NZS 60669.1

#### Multi-Gang de rating

Number of Dimmers	Max Load Per Dimmer
2	300W
3	250W
4	200W
5	150W
6	100W

*\*Note: Different brands of dimmable LED lamps/drivers have different dimming capabilities. The DM300S dimmer has been designed to adapt to a wide range of dimmable LED lamps/drivers. However, Voltex cannot guarantee compatibility with all LED lamps/drivers marketed as being compatible with trailing edge dimmers.*

#### Thermal cut-out

The dimmer has a thermal cut-out for overload and over-temperature protection. If the thermal cut-out operates, the dimmer can be reset as follows.

1. Disconnect power to the dimmer.
2. Determine and rectify the overload/over-temperature issue.
3. Turn power back on to automatically reset the dimmer.

#### Ripple Signal Injection

Some electricity utilities use communication signals injected onto power lines to remotely control devices such as off-peak water services. These signals are commonly found in parts of NSW and South East QLD. In areas where these 'ripple signals' are injected onto the mains supply, they may cause LED lights connected to dimmers to flicker intermittently.

Voltex dimmers have been designed to compensate for a nominal level of ripple signals. However, in areas where a high ripple signal amplitude is present, they can impact on the dimmer's ability to remove these signals. For more information regarding ripple signals, please contact the local electricity supplier.

#### Warranty

Voltex will not accept any warranty claims when the Voltex DM300S dimmer is used with non-Voltex branded lighting products. The DM300 dimmer is compatible with many leading brands of dimmable lighting products, however Voltex recommends checking compatibility between the dimmer and all 3rd party downlights or contact the Voltex technical support team to discuss suitability.

# Dimmer Installation



The dimmer's in-built push button switch is enabled by default, it can be disabled as follows:  
 With the lights ON, press the dimmer knob 4 times in quick succession. The dimmer knob backlight will flash 3 times to confirm the in-built switch is now disabled.

## Installation

### Installing the dimmer to operate with a separate, external switch

1. Disconnect power to the circuit.
2. Fit the DM300S Dimmer and a separate switch mechanism into a switch plate.
3. Connect the dimmer in the required mode (see below).
4. Reconnect power and confirm operation.
5. Change minimum dimming level setting if required (see table below).
6. Change other settings as required (see table below).

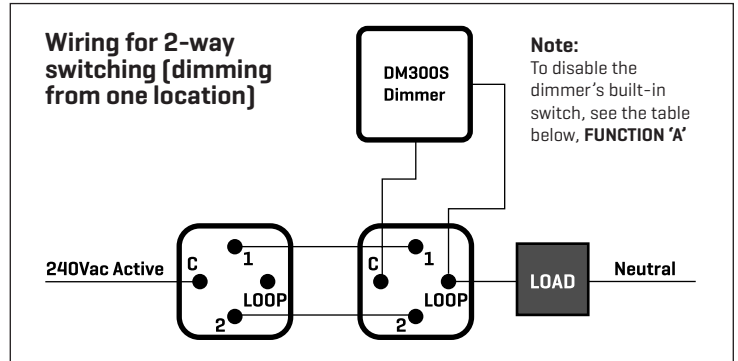
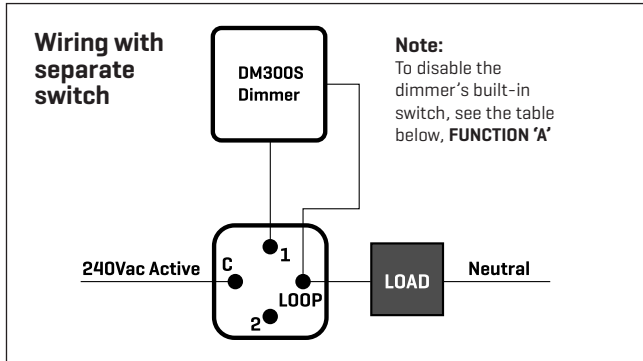

### Installing the dimmer to operate without an external switch (utilising the the integrated push-button switch for on/off)

1. Disconnect power to the circuit
2. Fit the DM300S into a wall plate
3. Connect the dimmer as shown in the diagram
4. Reconnect power and confirm operation
5. Adjust minimum dimming level as required (see table)
6. Adjust other settings as required (see table for all available settings)

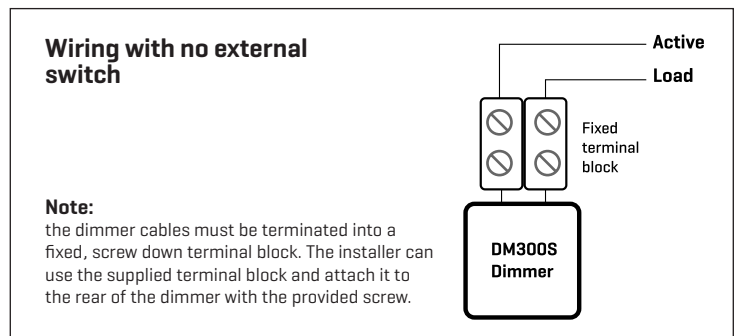

If required, the default settings can be altered as shown in the table below.

Function	Default	Instructions
<b>A</b>	<b>Enable/disable the in-built push-button switch</b>	Enabled With the lights ON/dimmer energised, press the dimmer knob <b>4 times</b> in quick succession. The dimmer knob backlight will flash 3 times to confirm the switch is now disabled.
<b>B</b>	<b>Adjust the minimum dimming level</b> NOTE: If the minimum brightness level is set below 20%, the lights will still switch on at 20%	20% With the lights ON, adjust the minimum brightness to the required level, then press the dimmer knob <b>5 times</b> in quick succession. The dimmer knob backlight will flash 3 times to confirm that the new minimum level has been saved.
<b>C</b>	<b>Adjust the maximum dimming level</b> NOTE: Maximum brightness can only be set between 70% and 100%	100% With the lights ON, adjust the maximum brightness to the required level, then press the dimmer knob <b>6 times</b> in quick succession. The dimmer knob backlight will flash 3 times to confirm that the new maximum level has been saved.
<b>D</b>	<b>Clear the current minimum and maximum dimming levels</b> NOTE: To set a new minimum, see Function B and to set a new maximum, see Function C	Min 20% Max 100% With the lights ON, press the dimmer knob <b>7 times</b> in quick succession. The dimmer knob backlight will flash 3 times to confirm that the minimum level is now 0% and the maximum level is now 100%
<b>E</b>	<b>Disable/Enable the dimmer knob backlight</b>	Enabled With the lights ON, press the dimmer knob <b>8 times</b> in quick succession. The dimmer knob backlight will flash 3 times to confirm that the dimmer knob backlight has been disabled.
<b>F</b>	<b>Reset all functions to factory defaults</b>	- With the lights ON, press the dimmer knob <b>9 times</b> in quick succession. The dimmer knob backlight will flash 3 times to confirm that the dimmer settings have been changed to factory defaults.
<b>G</b>	<b>Power-up ON/OFF*</b>	ON With the lights ON, press the dimmer knob <b>10 times</b> in quick succession. The dimmer knob backlight will flash 3 times to confirm that the power up state has been changed.

\*The dimmer is set to 'Power-up ON' by default. This setting is required when the dimmer is used with an external switch. If the dimmer is set to 'Power-up OFF' the lights will not turn on when the external switch is turned back ON. If no external switch is used, the power-up state can be set to OFF.

When the dimmer is set to power-up ON, the lights will switch back ON at the same level they were switched OFF at. NOTE: To ensure reliable operation, when the lights are switched OFF at a low dimmed level (less than 20%), the lights will always switch back ON at 20%