

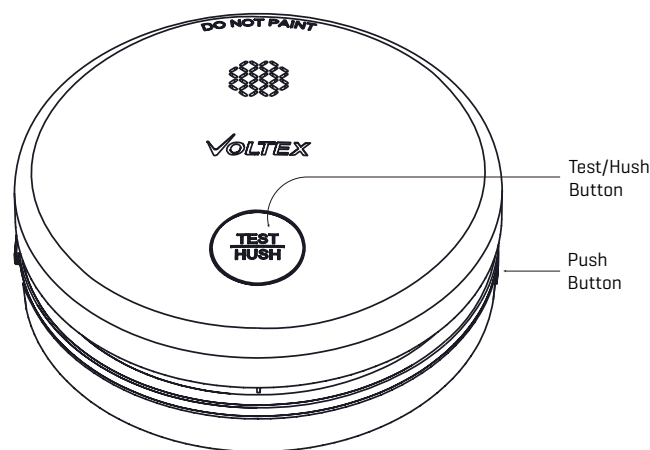

SASMH9V (No Wireless Module) SASMH9VRF (Inbuilt Wireless Module)

SMOKE ALARM INSTALLATION MANUAL

Buttons and Indicators



Please read these instructions carefully before installation and operation.

Sensing Type	Photoelectric (Type A - contains no radioactive material)
Power Supply	220-240V AC 50Hz Replaceable EVE DC Lithium battery
Interconnectivity	Hard Wired/ Wireless(Only SASMH9VRF)
Battery life	10 year backup Lithium (with mains power permanently connected)
Wireless Option	SASMH9VRF (Inbuilt Wireless)
Interconnection (Wired I/Connect)	Maximum 24 paired alarms Max wiring length between first and last alarm: 150 m
Interconnection (RF Connect)	Maximum 48 paired alarms, Max 100m (line of sight)
Size	Φ133mm x 48mm
Temp range	0°C - 45°C
Max Humidity	95% RH
"Alarm Signal Pattern"	ISO 8201
Alarm Volume	85dB at 3m
Hush Time	10 mins
Compliance	AS 3786: 2014+A1:2015+A2:2018

Important Safety Information

- This Voltex Smoke Alarm is designed for use in dwellings and shall be installed by a licensed electrician. It is intended to detect smoke before it reaches the occupants of a building. The ensuing alarm is designed to wake the occupants and give them time to evacuate the building.
- This smoke alarm SHALL be installed in accordance with national and local council building regulations and the latest edition of the Australian and New Zealand wiring Rules AS/NZS 3000. A simplified, by State, installation requirements guide is available on Voltex's website.
- The alarm cannot be operated from a non-sinusoidal power source, e.g. a square wave or modified sine wave inverter.
- For smoke alarm using scattered or transmitted light, the response threshold value band 1 or <0.2m dB/m.
- ALL ELECTRICAL WORK MUST BE CARRIED BY A LICENCED ELECTRICAL CONTRACTOR OR ELECTRICIAN.

Recommended Installation Locations

- At least one smoke alarm shall be fitted on each storey (including basements) - in each bedroom and in corridors or hallways which connect bedrooms and the rest of the dwelling or as required by relevant local legislation.

Scan this QR to download the PDF or follow this link

<https://voltex.co/sas-install-reg>



- Where practicable smoke alarms should be placed on the ceiling.
- It is important to install the smoke alarm in the center of the room, avoiding dead air spaces (an area in which trapped hot air will prevent smoke from reaching the alarm). Smoke alarms must not be placed within:
 - 300mm of a corner of a ceiling and a wall
 - 300mm of a light fitting
 - 400mm of an air-conditioning vent
 - 400mm of the blades of a ceiling fan
- Smoke alarms must be paired (interconnected) with every other smoke alarm so they all activate together.

SINGLE FLOOR

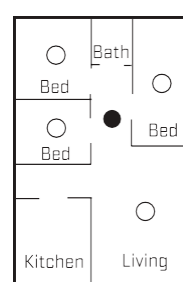

Figure B

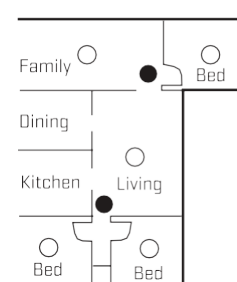
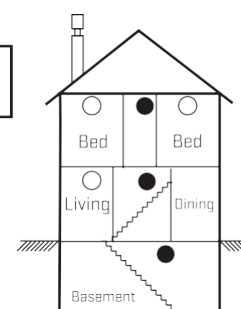

Figure C



● Minimum Protection

○ Additional Protection

Where it is not possible to place the alarm on the ceiling, the smoke alarm may be installed on the wall at a minimum of 300mm and a maximum of 500mm off the ceiling at the junction of the wall.

There are special requirements for stairways, sloping ceilings and ceilings with exposed beams. Specific requirements are explained in the relevant Building Regulation.

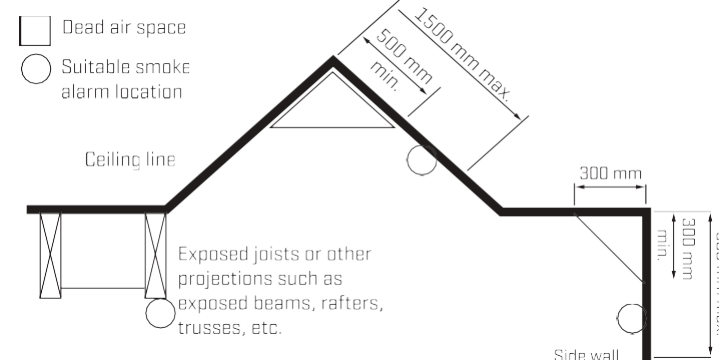

Nuisance Alarms

To reduce the likelihood of nuisance alarms, it is preferable that smoke alarms are not located near cooking appliances, bathrooms or laundries.

Wiring Diagram

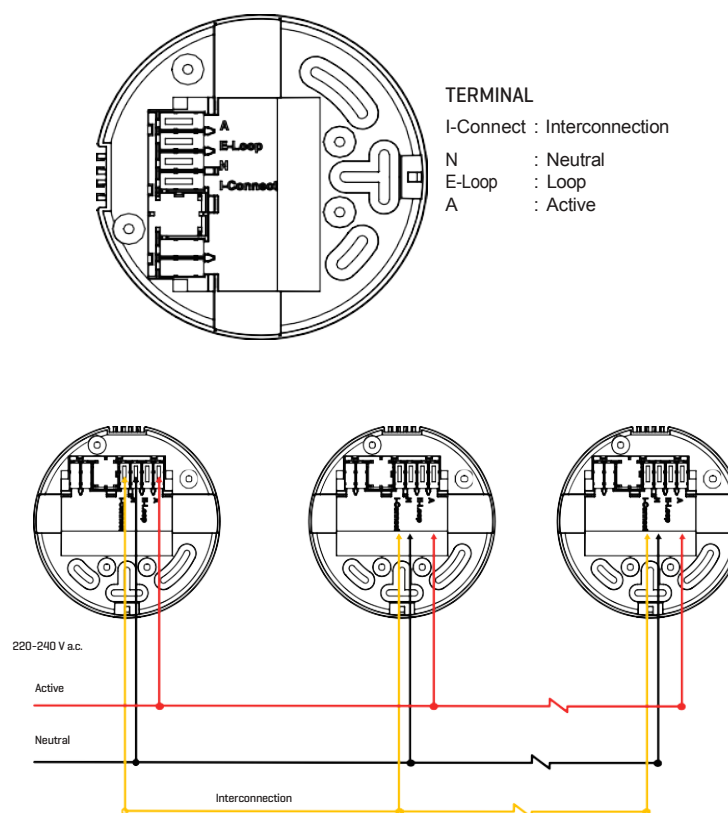

Smoke alarms must be installed in their own electrical subcircuit to avoid false alarms and nuisance chirping that may be caused by electromagnetic interferences from other electrical equipment.

- Do not connect high-power electrical appliances in the same circuit of the alarm
- The alarm cannot be operated from power derived from a square wave modified square wave or modified sine wave, inverter. These types of inverters are sometimes used to supply power to the structure in off grid installations, such as solar or wind derived power sources. These power sources produce high peak voltages that will damage the alarm.
- If connecting to a power source that utilises an inverter, e.g. PV solar panel, the Total Harmonic Distortion (THD) must be less than 6%.

Installation Procedure

1. Remove the battery isolation strip to connect the battery.
2. Select an appropriate location and facilitate necessary wiring.
3. Isolate the power supply and wire the appropriate power terminals on the back of the smoke alarm.
4. **If using Hard wire interconnection** wire the interconnecting cable. * Make sure the terminal cover is installed after wiring.
5. **If using wireless interconnection**, please see section on pairing before installing on ceiling.
6. Mount the smoke alarm in the ceiling with the supplied fixings and clip the smoke alarm shut.
7. Restore power to the smoke alarm circuit. A solid green LED indicates power is available.
8. Test the smoke alarm by pressing and holding the test button for min 3 seconds. If installed correctly and unit is functioning properly, an alarm should sound. If multiple alarms are installed, test the interconnection on all alarms.

System Interconnection

If more than one smoke alarm is installed all units shall be interconnected or paired. Follow State/Territory regulations. Interconnection can be achieved either by wiring the I-Connect terminals of the alarm together with another SASMH9V series smoke alarm, or by RF pairing using the optional wireless model SASMH9VRF

The SASMH9VRF smoke alarm can be wirelessly paired with the following Voltex Smoke Alarm models: SAS115BW ("01" series), SASH9VRF, SAS135MH with SASWM.



WARNING: DO NOT CONNECT INTERCONNECTION WIRE TO ACTIVE, NEUTRAL OR EARTH

NOTE: VOLTEX SMOKE ALARMS SHOULD NOT BE INTERCONNECTED WITH ANY OTHER BRANDS OF SMOKE ALARMS

Pairing SASMH9VRF (Wireless Model)

Note: Pairing (under battery power) is recommended prior to installation on ceiling.

1. Ensure all smoke alarms being paired are turned on
2. Assign 1 smoke alarm to be the "MASTER". Press the TEST button on this smoke alarm 3 times within 2 seconds to enter "Pairing Mode". Note: The Alarm LED will illuminate solid Red & the unit will remain in pairing mode for 50 seconds. This unit now becomes the MASTER smoke alarm. It remains in pairing mode for 50 seconds from the last successful pairing.

Warning: Only create one MASTER per installation.

NOTE: Clearly mark the "Master" unit to enable easy future identification.

3. On any other "SLAVE" smoke alarm, press the TEST button 3 times within 2 seconds to enter pairing mode.

If the network connection is successful: Both the Master & the Slave units will do one short chirp and the SLAVE unit LED will extinguish.

4. Once all units that are being wirelessly paired are complete, wait for 1minute for the Red LED on the Master 240V unit to turn off. Indicating it has Exited pairing mode.
5. NOTE: Ensure the pairing light is still illuminated on the Master unit just before each pairing action to avoid creating multiple groups.

NOTE:

If wirelessly (RF) connecting one 240V smoke alarm to another 240V smoke alarm, do not also use a hard wire Interconnection between these two 240V smoke alarms.

NOTE:

1. Interconnection wire shall be no less than 1.5mm2 and shall be SDI cable*
2. Smoke alarms which are interconnected using hard wiring must be on the same circuit.

Do not connect high-power electrical appliances in the same circuit of the alarm.

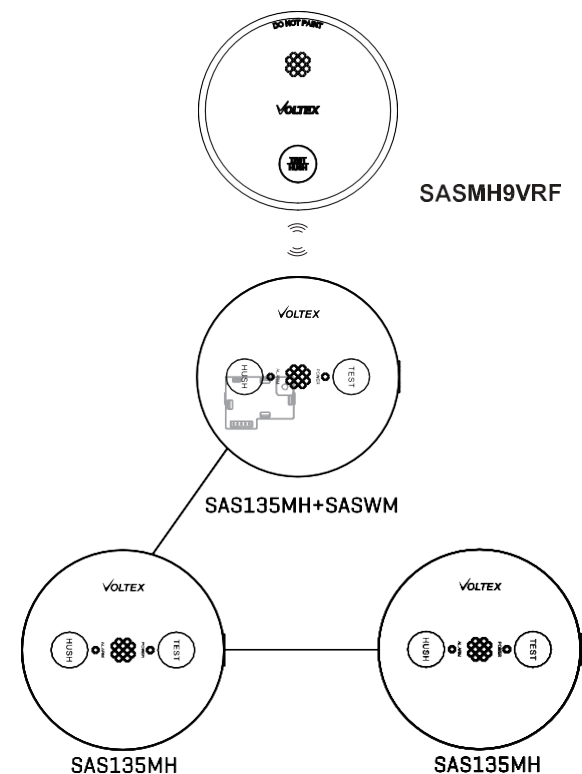

Pairing a Wireless Smoke Alarm Remote

Refer to SASREM Product Installation Manual



<https://voltex.co/saswm>
Scan for SASWM Product



<https://voltex.co/SASREM>
Scan for SASREM Product

HUSH Mode

In the event of an alarm condition, pressing the HUSH button on the alarm unit will silence the alarm for approximately 10 minutes.

NOTE: Where multiple alarms are interconnected, the HUSH function WILL NOT OPERATE EXCEPT ON THE UNIT THAT THE ALARM WAS TRIGGERED FROM. The triggered unit can be identified by the RED LED flashing.

Do Not Disturb Mode

When the unit indicates a low battery alarm or internal fault, pushing the HUSH button will silence the alarm for 10 hours and the red LED will flash twice every 48 seconds.

Test Procedures For Hardwired Interconnection

1. Ensure the green LED is continuously illuminated on each unit, this indicates 240V mains AC power is available.
2. Pressing and holding the test button on any smoke alarm for at least 5 seconds will activate an alarm and cause the red LED on the front face to flash.
(Note: all other interconnected smoke alarms will stop alarming when releasing the Test button, but the red LED will flash for 3 minutes.)
3. Repeat this procedure for each alarm.
Note: The sending/test unit will only sound on initial pressing, not together at same time as the receiving units, and the red LED will flash twice every 48 seconds.

SASMH9VRF

Removing/Clearing Wireless Pairing

1. Disconnect AC power by unclipping the unit from the base; remove the battery.
2. Press and hold the Test/Hush button & continue to press.
3. Re-install the battery while still pressing the test button.
4. After holding the button in for 3 seconds, the RED light on the front will light up.
5. Continue to hold the button in until the Red light turns off.
6. Now release the button within 3 seconds; the Red light should light up again.
7. When the Red light turns back on, press the Test button once,
8. If the wireless clearing is successful, the Red light will flash once and the smoke alarm will chirp three times.

AVOID THESE LOCATIONS:

- In the garage: dust, insects & car fumes can cause nuisance triggering.
- In areas where the temperature may fall outside 0°C - 45°C.
- In dusty areas. Dust particles may cause nuisance alarm or failure to alarm.
- In very humid areas (greater than 95% R.H.). Moisture or steam can cause nuisance alarms.
- In insect-infested areas.
- Smoke alarms should not be installed within 3 ft (0.9m) of the following: the door to a kitchen, the door to a bathroom containing a tub or shower, forced air supply ducts used for heating or cooling, ceiling fans or other high air flow areas.
- Near fluorescent lights. Electronic "noise" may cause nuisance alarms.

Product Function Description		
Function	Indication	Description
Standby status (Normal operation)	Red LED flashes every 48 seconds.	Normal operation.
AC power indication	Green LED illuminates continuously.	AC power connected.
Low battery warning	The unit chirps & Red LED flashes once every 48 seconds.	Low battery voltage- replace with a new battery within 30 days.
Fault warning	The unit beeps twice and flashes twice every 48 seconds	The unit is faulty- refer to "Trouble Shooting" section.
No wireless interconnection indication	Red LED flashes twice every 8 seconds.	Continues for 5minutes after power up (Model SASMH9VRF)
End-of-life warning	The unit chirps & Red LED flashes twice every 48 sec.	The unit will send end-of-life warning after working 10 years. Need to replace with a new smoke alarm.
Test function	Red LED flashes once every second with alarm sounding until the TEST Button is released.	<ul style="list-style-type: none"> Test by pressing the TEST button on the smoke alarm at least 5 seconds. The alarm will sound if all working properly. If no alarm sounds, refer to "Trouble Shooting". Recommend testing the alarm Weekly by pressing the TEST button.
Hush Mode	The Red LED flashes every 8 seconds.	<ul style="list-style-type: none"> This smoke alarm has a built-in Silence feature. If cooking or other non-hazardous sources cause the alarm to sound, it can be temporarily silenced by pressing the HUSH button for more than 2 seconds. The alarm enters Hush mode for 10 minutes. After the 10 minute dormant period, the smoke alarm will resume normal operation.
Alarm Triggered	The Red LED flashes every second with alarm sound.	Generate alarm sounds when fire happening
Alarm Memory	The Red LED Flashes twice every 24 seconds	After the unit triggers, it enters the alarm memory state, and the red LED flashes twice every 24 seconds for one week.
Interconnection alarm	The unit generate alarm sounds without Red LED flashing.	The unit will enter the interconnection alarm mode when received wire interconnection alarm signals or wireless alarm signals.
Interconnection alarm memory	The Red LED flashes once every 1 second.	After the unit exits Interconnection alarm state, it enters Interconnection alarm memory state, and the red LED flashes once every 1 second for 3 minutes.
Do not disturb function	The Red LED flashes twice every 48 seconds	The unit will stop nuisance warning for 10 hours under low battery or fault mode when HUSH button is pressed.

*Continuous alarm pattern: Beep 0.5s- Pause 0.5s- Beep 0.5s- Pause 0.5s-Beep 0.5s- Pause 1.5s repeatedly per ISO 8201 Smoke is detected, and the building must be vacated immediately. Emergency services must be notified.

Maintenance

- Periodically apply the Test Procedure to test the alarm.
- Smoke Alarm are prone to dust and insect ingress which can cause false alarm, it is prudent to clean the smoke alarm periodically. The Smoke Alarm must be kept clean so that excess dust does not build up. Any insects or cobwebs in the vicinity of the Smoke Alarm should be promptly removed. Vacuum the outside of the Smoke Alarm to remove any dust build up.
- Do not spray any cleaning liquids directly onto the smoke alarm.

Alarm Memory

The Red LED on the triggered alarm flashes TWICE every 24 seconds for one week. This can be used to identify the triggered unit. The memory will last for 7 days from the last trigger event. Removing the battery will pause the memory, not delete it.

Trouble Shooting

Problem	Solution
Green LED not lit	Check mains power connection If green power light still not visible, perform a re-start: Remove the battery, press Test button twice, re-install battery.
Hard wire I/Connected smokes don't alarm during test	Check if Smoke Alarms are in same circuit, interconnect cable is corrected firmly and mains power is connected.
Wireless interconnected smoke alarms don't alarm during test	Check if the other smoke alarms are not still in Test mode from previous test.
Alarms sound for no apparent reason	<p>Check for fumes, steam, etc. from the kitchen or bathroom. Paint and other fumes can cause nuisance alarms. Check for any sign of contamination such as cobwebs or dust. Clean the alarm.</p> <p>Press the local Hush button to silent the Smoke Alarm triggered, identify the alarm that triggered by the flashing red LED (alarm will not silence if it does not have a flashing red LED)</p> <p>If cannot hush the smoke alarm, push the button located on the side and open the Smoke Alarm, take the battery out. Contact Voltex.</p>
1x Chirp every 40 seconds and cannot hush	Check if battery has been installed firmly, Install new 9V battery. Contact Voltex if ongoing issue.
Dust and insect Contamination	Vacuum the outside of the Smoke Alarm to remove any dust build up. Smoke Alarm are prone to dust and insect ingress which can cause false alarm, it is prudent to clean the smoke alarm periodically.

SMOKE ALARM FAULT FINDING

Scan this QR to watch the video or follow this link
<https://voltex.co/sasvid>



Call 1300 722 275 for assistance.

System Configuration

CONFIG 1 - 1 Circuit

Hardwire Interconnect Only, On 1 Circuit

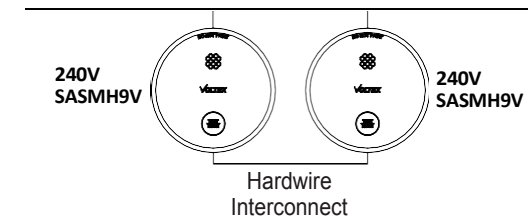

CONFIG 2 - 1 Circuit

Hardwire & Wireless Interconnect, 1 Circuit

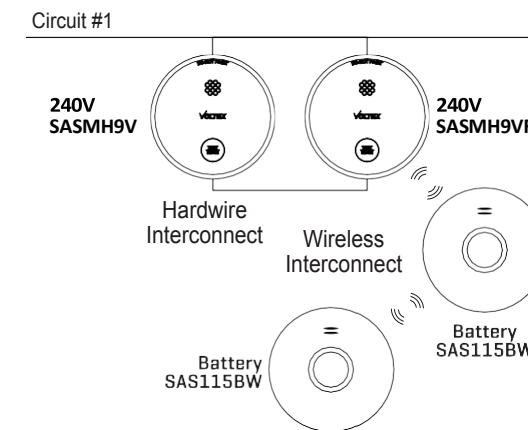

CONFIG 3 - 2 Circuits

Wireless Interconnect Only, 2 Circuits

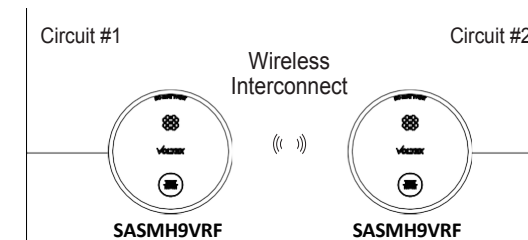

DO NOT HARD WIRE I/CONNECT ACROSS 2 CIRCUITS

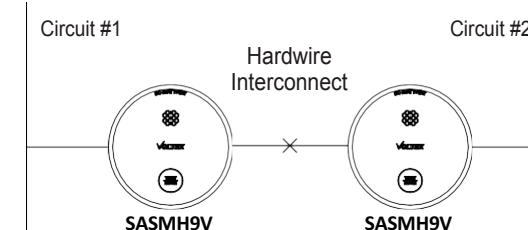

Replacing the battery

- The smoke alarm incorporates a replaceable battery (CR9V) which is designed to power the smoke alarm in the event of a short-term power outage. The battery is designed to last 10 years subject to normal use and regular maintenance from the date of manufacture and can be replaced by opening the smoke alarm and accessing the battery under the battery cover

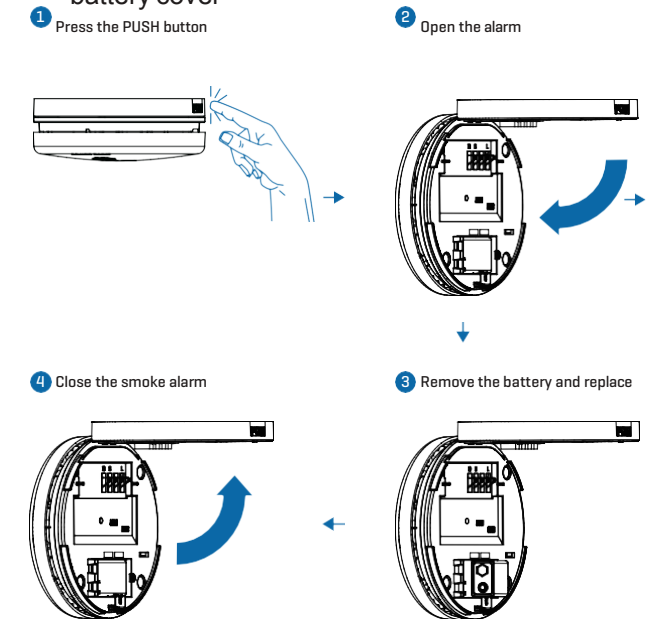

WARNING: CANNOT BE CONNECTED TO VOLTEX SAS135MH (240V with 3V Battery) MODEL SMOKE ALARM VIA I/CONNECT WIRE*

Warranty Information

Voltex warrants this accessory against defective workmanship and faulty materials for seven (7) years from the original date of purchase.



AU: 1300 722 275
 NZ: 0800 55 66 33

sales@voltex.com
 www.voltex.com