

Switchboards White Door Flush Mounting

Voltex Flush Mounting Switchboards are made with high quality fire resistant plastic. All Voltex switchboards can incorporate the complete Voltex line of circuit breakers & RCBOs depending on your job requirements.

Flush Mounting, 12 way Code: SBF-12W



Dimensions:

Cover:

305mm[W] x 247mm[H] x 35mm[D]

Box:

255mm[W] x 191mm[H] x 78mm[D]

Flush Mounting, 18 way Code: SBF-18W



Dimensions:

Cover:

415mm[W] x 270mm[H] x 30mm[L]

Box:

380mm[W] x 240mm[H] x 78mm[L]

Flush Mounting, 24 way Code: SBF-24W



Dimensions:

Cover:

303mm[W] x 357mm[H] x 30mm[D]

Box:

253mm[W] x 311mm[H] x 78mm[D]

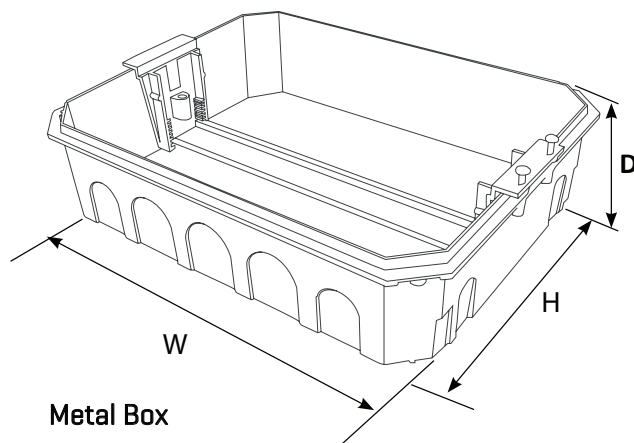
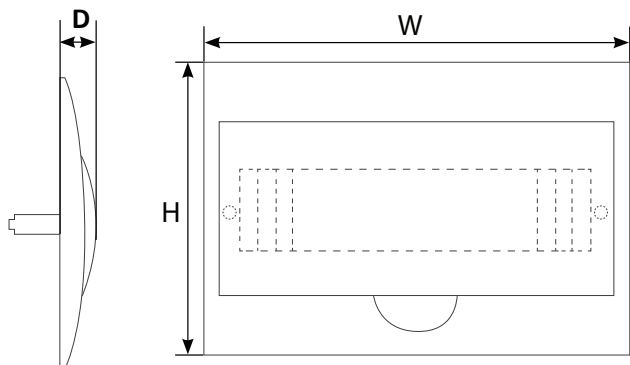

SS-020217