

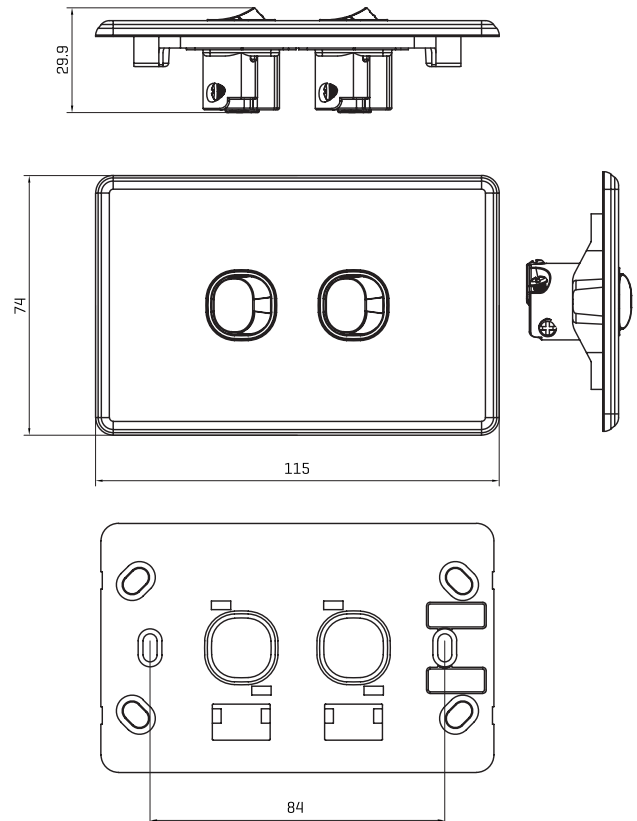

Technical Specifications:

Plate Thickness:	4.7mm
Mounting Centre:	84mm
Plate Size:	74mm [W] x 115mm [H]
Mechanism:	Voltex CSM16 16AX <i>[for more details on mechanism, see CSM16 specification sheet]</i>
Material:	Polycarbonate
Colours:	White, Black
Orientation:	Available in vertical and horizontal

Dimensions:



Compliance:

AS/ NZS 3133

Shadowline

