

Promat

Promat Australia Pty. Ltd.

SYSTEM CERTIFICATE*

This is to certify that
PROMASEAL® Conduit Collar on walls
 has been tested/approved in accordance with
 Australian Standard 1530: Part 4: 1997
 methods for fire tests on building materials, components and structures,
 and
 Australian Standard 4072: Part 1: 1992
 components for the protection of openings in fire
 resistant separating elements

Masonry wall shown, 2hr Plasterboard Systems also applicable

PIPE	SIZE	FRL	REPORT
uPVC	25	-/180/90	FSPO 643
uPVC	32	-/180/90	FSPO 643
PB	18	-/180/180	WFRA 21138
PB	22	-/180/180	WFRA 21138
PEX	16	-/180/180	WFRA 2253502
PEX	20	-/180/180	WFRA 2257300
PEX	25	-/180/120	WFRA 2257300
PEX-L	16	-/180/180	WFRA 21138
PEX-L	20	-/180/180	WFRA 21138
PEX-L	26	-/180/180	WFRA 21138
PEX-C	16	-/180/180	WFRA 41195
PEX-C	20	-/180/120	WFRA 41195
PEX-C	26	-/120/-	WFRA 41195
PEX-AL-PE	16	-/180/30	WFRA 41195
PEX-AL-PE	20	-/180/30	WFRA 41195
PEX-AL-PEX	16	-/180/180	WFRA 2257300
PEX-AL-PEX	20	-/180/60	WFRA 2257300
PEX-AL-PEX	25	-/180/30	WFRA 2257300
PEX-AL-PEX	32	-/180/60	WFRA 2257300

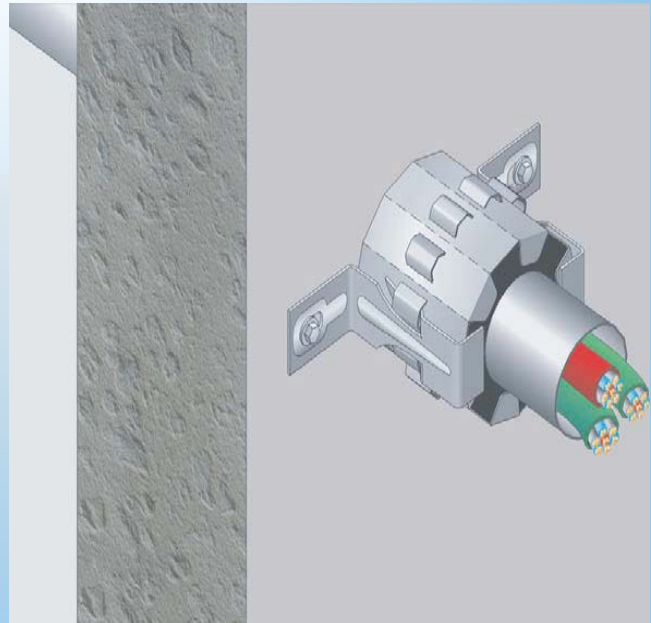

* This is NOT a test certificate. For installation instructions or further information please contact Promat Australia Pty. Ltd.

Dial: 1800 PROMAT (776628) Email: mail@promat.com.au Visit: www.promat-ap.com